

| REVISIONS | | | | |
|-----------|-----|-------------|------|----------|
| ZONE | REV | DESCRIPTION | DATE | APPROVED |
| | | | | |

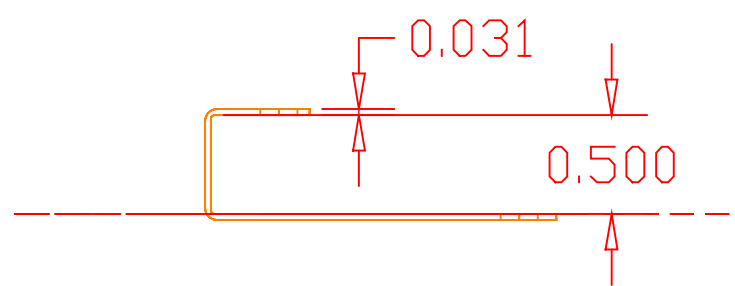
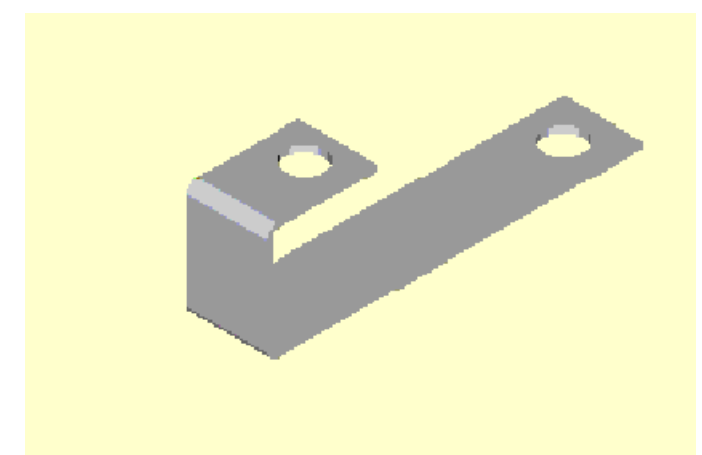
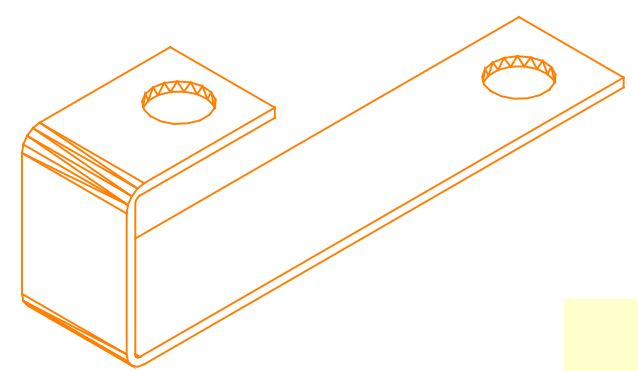
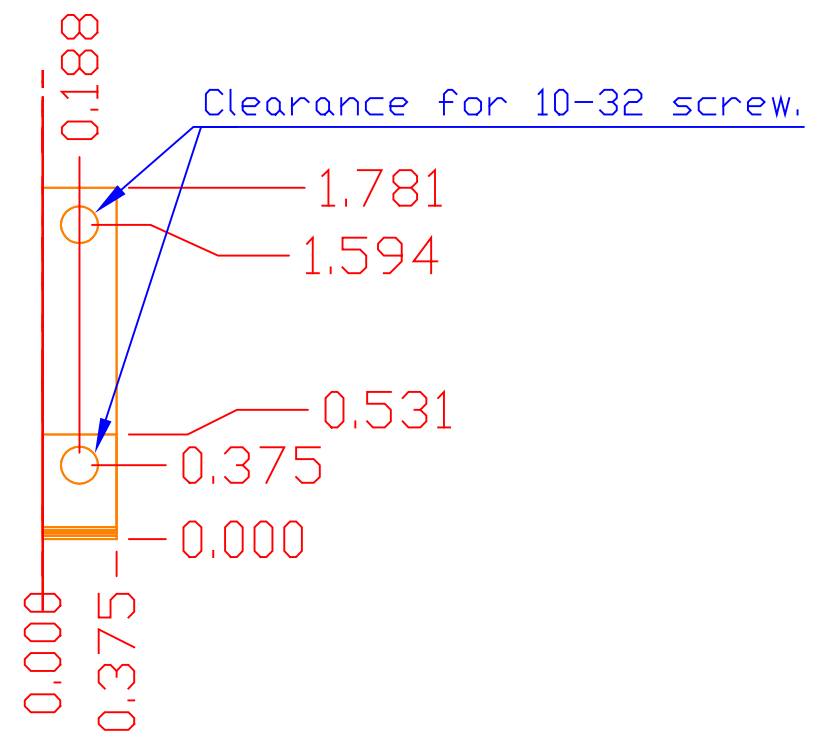
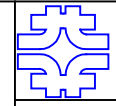

NOTE: Pieces are to be bright tin plated.
1/32" OFHC COPPER

| | | | | |
|---|---|----------|-------------------------------|-------|
| PPD/ETT/D0 Electronics Group David L. Huffman |  FERMI NATIONAL ACCELERATOR LABORATORY UNITED STATES DEPARTMENT OF ENERGY | | | |
| | Calorimeter Electronics Upgrade Preamp Power Supply AC Fuse Connection Copper Strap | | | |
| | SIZE B | FSCM NO. | DWG NO. 3823.121.MB-330255 | REV |
| 03/03/99 | SCALE 1:1 | | | SHEET |